

# Schindler 400A<sup>®</sup> Machine Room Side Traction elevator installation checklist



# Schindler 400A<sup>®</sup> Machine Room Side Traction elevator installation checklist

## Delivery of equipment

Prior to elevator equipment delivery, an enclosed dry hoistway, a ready control room, and temporary or permanent three-phase power must be available.

## General Contractor

- Provide adequate, rollable access for delivery and material unloading, and a dry place for storage of equipment located near hoistway.
- Refer to elevator layout. Please verify hoistway finished clear width and depth, pit depth, floor-to-floor heights, and clear overhead.

- Build a clear, plumb, legal hoistway in accordance with applicable code from top-to-bottom with variations not to exceed 1" (25.4 mm) per side in the first 100' (30480 mm). Tolerance may increase at 1/32" (0.8 mm) for each additional 10' (3048 mm) up to a maximum of 2" (50.8 mm).
- Provide attachment points for elevator rail brackets. Locate per layout.
- Divider beams are required between adjacent elevators at all floor levels and one or two locations above top floor in the overhead (application dependant). Locate per layout.

- C1** – Check local codes for ventilation requirements. Refer also to Ventilation Requirements on back page.
- C2** – Supply hoist beams for elevator construction and service work. Beams to run across the width of the elevator shaft. Locate per layout.
- C3** – Elevator rail bracket supports (inserts, steel, or concrete) are needed at all floor levels, in the overhead and at other locations as required by code. Locations to be coordinated with Schindler.

## C4 Hoistway walls at entrances:

- Masonry: Provide opening of +8" (203 mm) on each side and +8" (203 mm) on top of clear opening for installation of door frames and sills by Schindler.
- Dry wall: Walls at entrance to be built after door sills and frames are set in place.
- Refer to elevator layout and entrance drawings during construction.
- Grout entrances and sills after installation by Schindler.

- C5** – Provide fire-rated, self-closing, self-locking control room door.

- C6** – Control room temperature must be maintained between 55°F (13°C) and 90°F (32°C) for proper operation of equipment.

- C7** – Provide governor access door in hoistway wall. Locate per layout.

- C8** – Provide 6" W x 12 H" (152 mm x 305 mm) blockout for wire ducts. To be sealed by General Contractor. Location to be coordinated with Schindler.

- C9** – OSHA-approved barricades must be installed with kick board at each opening.

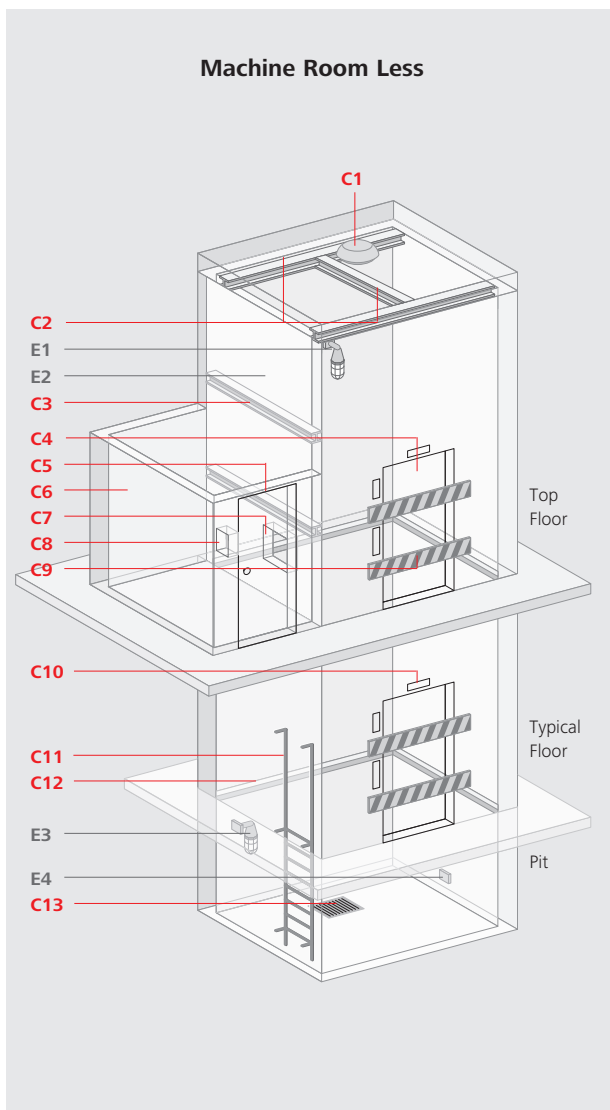

- C10** – If job requires cutting and patching of walls, floors, etc., and removal of such obstruction for proper installation of the elevator as well as pockets or blockouts for signal fixtures, it is to be done by General Contractor. Refer to elevator layout. Seal all wall penetrations with material approved by code to maintain fire rating.
- C11** – Provide pit ladder — location per layout.
- C12** – Bevel all hoistway projections and recesses in accordance with applicable codes.
- C13** – Provide drain or sump hole in pit as required by governing local code. Cover for sump shall be level with pit floor. Drains connected directly to sewers shall not be installed in elevator pits. Location to be coordinated with Schindler.

### Electrical Contractor

- If sprinklers are required, provide smoke sensing devices at elevator lobbies and/or at top of elevator shaft with electrical conductors terminating at elevator controller in control room for automatic elevator recall system in the event of a fire.

#### Control room:

- E1** – Provide adequate lighting and receptacle in control room and elevator overhead/machinery space. Locate per layout.
- E2** – Shunt trip breaker required if sprinkler in pit, hoistway or control room.
  - Must immediately confirm the type of three-phase power to the elevator equipment room (208 volt, 230 volt, 240 volt, 460 volt, 480 volt, 575 volt or 600 volt) and provide before work can begin. Refer to Schindler power data sheet for approval.
  - Provide a fused heavy duty three-phase lockable disconnect or shunt trip breaker and single-phase lockable disconnect (for car lighting and fan) in control room with feeder branch wiring to elevator controller. Disconnect size to suit elevator contractor’s equipment requirements. All work must be per National Electric Code and ASME A17.1 and any local codes. Locate per layout.
- E3** – Provide a light and receptacle in elevator pit.
  - Per the latest National Electrical Code, all receptacles installed in control rooms, machinery spaces and pits must have Ground Fault Circuit Interrupter Protection (GFCI).

- E4** – Provide installation power supply at bottom landing.
  - A temporary, 220V, single phase, 30Amp GFCI protected circuit to each group of elevator hoistways for installation work. Refer to Schindler power data sheet for approval.

### Schindler Elevator Corporation

- Supplies telephone in car and travel cable to car.

All wiring (including analog phone line) to machine room supplied by owner.

**Local codes may vary. Consult with your architect/ engineer and local Schindler representative.**

# Schindler 400A<sup>®</sup> Machine Room Side Traction elevator installation checklist

## Ventilation requirements

The following guidelines are to be followed to maintain acceptable temperature ranges and insure proper operation of equipment:

1. Control room temperature must be maintained between 55° (13°C) and 90°F (32°C) and less than 95% humidity, non-condensing.
2. A vented door should be avoided. Air removal should be done by ducting the air from the room to the outside if possible. A forced removal of the air to another part of the building or building exterior is needed to keep an air exchange through the control room. Intake and exhaust vents should not be located next to each other.
3. Overhead machinery space temperature at top of hoistway to be maintained between 32°F (0°C) and 122°F (50°C) and less than 95% humidity, non-condensing.

HP	Control and Drive BTU/h	Machine BTU/h	Current @ 480VAC (A)*	
			Running	Accelerating
10.3 (7.7 kW)	6705 (1965 W)	1075 (315 W)	17.1	22.4
15.4 (11.5 kW)	9290 (2723 W)	1605 (470 W)	24.6	33.8
21.6 (16.1 kW)	12435 (3644 W)	2250 (659 W)	28.8	46.1
25.3 (18.9 kW)	14490 (4244 W)	2635 (772 W)	33.8	52.6
30.0 (22.4 kW)	16875 (4946 W)	3125 (915 W)	37.6	53.4

\* Approximate; consult power data for exact application details and current values for other than 480VAC.

For further information including location of the Schindler office nearest you, please visit:

**[www.us.schindler.com](http://www.us.schindler.com)**

North American Headquarters  
Morristown, New Jersey 07962-1935  
Tel. 973.397.6500